



**IN THE UNITED STATES PATENT AND TRADEMARK OFFICE**

In re Application of: Rich Baranski

Serial No.: 10/055,757

Filed: January 22, 2002

Title: Adjustable Door Guide Latch Slot Assembly

Examiner: Lugo, Carlos

Group Art Unit: 3676

**APPEAL BRIEF**

Mail Stop Appeal Brief - Patents  
Commissioner for Patents  
P.O. Box 1450  
Alexandria, VA 22313-1450

Sir:

This Appeal Brief is being filed in triplicate together with a check in the amount of \$500 to cover the appeal fee and a second check in the amount of \$1,020 to cover a three month extension of time under 37 C.F.R. 1.136(a). If this fee is deemed to be insufficient, authorization is hereby given to charge any deficiency (or credit any balance) to the undersigned deposit account 503289.

This is an appeal from the decision dated May 12, 2006 finally rejecting claims 1-10, 14-17 and 22 under 35 U.S.C § 103(a) as being unpatentable over U.S. Patent No. 3,976,317 issued to Collier (hereafter "Collier") in view of U.S. Patent No. 2,124,970 issued to Bagley (hereafter "Bagley") and finally rejecting claims 11-13 and 18-21 under 35 U.S.C. § 103(a) as being unpatentable over Collier in view of Bagley and further in view of U.S. Patent No. 5,757,269 issued to Roth, et al. (hereafter "Roth").

**REAL PARTY IN INTEREST**

The real party in interest is U-Haul International, Inc., the assignee of the subject application.

**RELATED APPEALS AND INTERFERENCES**

None.

## STATUS OF CLAIMS

Claims 1-22 are pending in the application, have been finally rejected, and are the subject of this appeal.

## STATUS OF AMENDMENTS

Claims 1-22 have not been amended after the final rejection of May 12, 2006.

## SUMMARY OF THE CLAIMED SUBJECT MATTER

A large number of commercial and residential buildings and facilities use vertically sliding overhead doors for a variety of applications such as garage doors, exterior doorways, and doorways into storage rooms. Typically, these overhead doors travel in door frames or door guides that are permanently affixed to the material of the walls that form the doorway or other opening covered by the overhead door when the overhead door is in a closed position. The overhead doors move vertically up and down between the door guides. Rollers are often placed on the outer edges of the overhead doors in contact with the inner surface of the door guides to facilitate the up and down movement of the overhead doors.

When in a closed position, such overhead doors are often latched shut by a slidable latch mechanism. The latch mechanism is permanently affixed to the vertical door and, when in a closed position, has a slidable latch tongue that passes through an opening in the door guide. The need for a secure fit between the latch tongue and the door guide opening through which the latch tongue passes when the latch is in a closed or locked position is frequently hindered by height variations between the installation of the door guide and the overhead door. Even very slight variations in the installation of this hardware can result in situations where the latch tongue will not line up with the door guide opening, thereby preventing the latch tongue from being moved into its closed position.

Accordingly, a need exists for an adjustable door guide latch mechanism to compensate for door hardware installation height variations that would otherwise prevent proper operation of a slidable door latch mechanism. Moreover, a need exists for an adjustable door guide latch slot assembly that will be easy to install and will not interrupt the smooth operation of the vertical door with which it is associated.

According to the present invention, an adjustable door guide latch slot assembly for aligning a slidable door latch with a fixed door guide includes a striker plate having a latch

opening and a door guide having an inner surface with a recessed area on the inner surface. The recessed area is larger than the striker plate and has an opening therein. The striker plate can be placed flat against the door guide inner surface in the recessed area and adjustably affixed to the door guide inner surface so that the striker plate latch opening may be made to align properly with the slidable door latch.

Without limiting the scope of the claimed invention in any way, the independent claims on appeal are discussed as follows:

Claim 1 is directed to an adjustable door guide latch slot assembly 10 for aligning a slidable door latch 34 with a fixed door guide 20. The assembly 10 includes a striker plate 12 that can be adjustably affixed directly to the door guide inner surface 22 so that the striker plate latch opening 14 aligns with the slidable door latch 34. *See* specification at page 2, line 25 to page 3, line 14.

Independent claim 14 is directed to an adjustable door guide latch slot assembly 10 for aligning a slidable door latch 34 with a fixed door guide 20. The assembly 10 includes a striker plate 12 having a latch opening 14 and a door guide 20 adapted to retain a door therein so that the door can move slidably along a length of the guide 20 when the door is retained in the guide 20. The guide 20 includes an inner surface 22 with a recessed area 28. The striker plate 12 can be placed flat against the door guide inner surface 22 in the recessed area 28 and adjustably affixed to the door guide inner surface 22 so that the striker plate latch opening 14 aligns with the slidable door latch 34. *See* specification at page 2, line 25 to page 3, line 18.

Independent claim 19 is directed to an adjustable door guide latch slot assembly 10 for aligning a slidable door latch 34 with a fixed door guide 20. The assembly 10 includes a striker plate 12 having a latch opening 14 and a door guide 20 adapted to retain a door 32 therein so that the door 32 can move slidably along a length of the guide 20 when the door is retained in the guide 20. The guide 20 includes an outer surface 24 and an inner surface 22 with a recessed area 28. The striker plate 12 may be placed flat against the door guide inner surface 22 within the recessed area 28 and may be adjustably affixed to the door guide inner surface 22 so that the striker plate latch opening 14 aligns with the slidable door latch 34. The recessed area 28 has an opening 26 extending from the inner surface 22 to the outer surface 24. *See* specification at page 2, line 25 to page 3, line 18. A security device 42 includes a latch receiving port 44 and is affixed to the adjustable striker plate 12 so that the latch receiving port 44 aligns with both the

striker plate latch opening 14 and the slidable door latch 34. *See* specification at page 3, lines 19-30.

Independent claim 22 is directed to a method of adjustably aligning a latch slot 10 in a fixed door guide 20 with a slidable door latch 34. The method includes the steps of: providing a striker plate 12 having a latch opening 14; and providing a door guide 20 having a channel sized to retain a door slidably therein. The striker plate 12 can be adjustably affixed to the door guide inner surface 22 so that the striker plate latch opening 14 aligns with the slidable door latch 34.

#### GROUPS OF REJECTION TO BE REVIEWED ON APPEAL

1. Is the subject matter of claims 1-10, 14-17, and 22 obvious under 35 U.S.C § 103(a) over Collier in view of Bagley?
2. Is the subject matter of claims 11-13, and 18-21 obvious under 35 U.S.C § 103(a) over Collier in view of Bagley, and further in view of Roth?

#### GROUPING OF THE CLAIMS

The grouping of claims is as follows:

Claims 1, 4-10, 16-17 (an adjustable door guide latch slot assembly having a striker plate that can be adjustably affixed to a door guide inner surface so that the striker plate latch opening aligns with the slidable door latch) and 22 (a method of adjustably aligning a latch slot in a fixed door guide with a slidable door latch whereby the striker plate can be adjustably fixed to the door guide inner surface);

Claims 2, 3, 14 and 15 (an adjustable door guide latch slot assembly having a recessed area on the door guide inner surface);

Claims 11-13 and 18 (an adjustable door guide latch slot assembly having a strike plate that can be adjustably affixed to a door guide inner surface and also having a security device);  
and

Claims 19-21 (an adjustable door guide latch slot assembly having a recessed area on the door guide inner surface and also having a security device).

The claims do not stand or fall together. Each of the foregoing groupings will be argued separately below.

## ARGUMENT

1. The Subject Matter of Claims 1-10, 14-17, and 22 Is Not Obvious Under 35 U.S.C § 103(a) Over Collier in View of Bagley<sup>1</sup>

The Examiner asserts that claims 1-10, 14-17 and 22 are obvious over Collier in view of Bagley. Applicant respectfully submits that Collier and Bagley do not render these claims unpatentable because the Examiner has presented no motivation to combine the cited references and because, in any event, Collier and Bagley do not disclose all of the features of the claims.

Each of claims 1-10 and 14-17 is directed to an adjustable door guide latch slot assembly for aligning a slidable door latch with a fixed door guide. The assembly includes a striker plate having a latch opening therein and a door guide adapted to retain a door therein such that the door can move slidably along a length of the guide when the door is retained in the channel. The guide includes an inner surface and an opening therein. The striker plate can be adjustably affixed directly to the door guide inner surface so that the striker plate latch opening aligns with the slidable door latch. Claim 22 is directed to a method of adjustably aligning a latch slot in a fixed door guide with a slidable door latch. The method includes providing a striker plate that can be adjustably affixed to the door guide inner surface so that the striker plate latch opening aligns with the slidable door latch.

FIGs. 3 and 5 from Applicants' application are shown below for convenience.

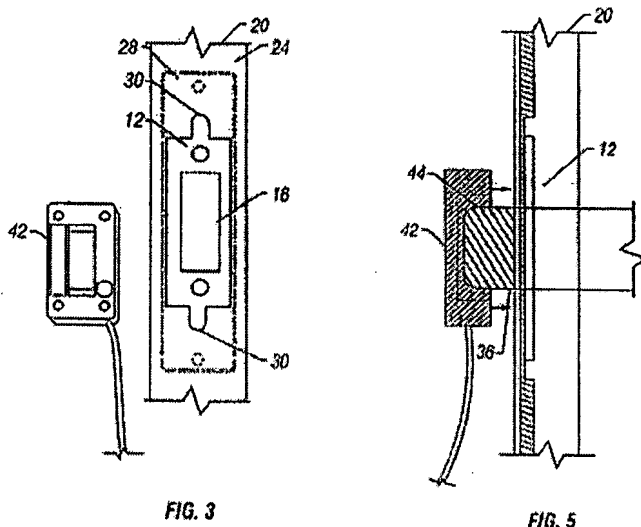

<sup>1</sup> Claims 1, 14 and 22 are independent claims. Claims 2-10 depend, either directly or indirectly, from claim 1. Claims 15-17 depend, either directly or indirectly, from claim 14.

Collier is directed to a strike plate construction for a sliding glass door or window, not an overhead door. In rejecting the claims, the Examiner has argued that Collier discloses an adjustable door guide latch slot assembly comprising a striker plate (21) having a latch opening (26) and a door guide having a vertical channel formed by flanges (47, 48) projecting from a vertical planar surface (23) (see Attachment 1 to Office Action dated January 19, 2005). FIG. 1 of Collier is shown below for convenience.

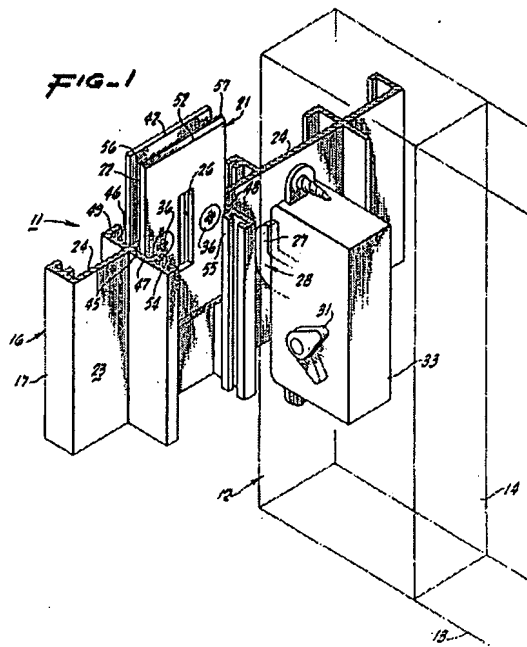

As can be seen from FIG. 1 of Collier, the edge of the glass door (14) is retained in the door guide channel only when the door is in the closed position. In that closed position with the door retained in the channel, however, the door cannot move slidably along the vertical guide channel. Thus, Applicant respectfully submits that the Collier door guide (as defined by the Examiner in Attachment 1 to the Office Action of January 19, 2005) is not a guide adapted to retain a door slidably therein, as recited in claims 1-10, 14-17 and 22. To the contrary, the door of Collier is designed to slide horizontally in a track that is not even shown in FIG. 1 and only when the door is not retained in the guide channel.

Bagley is directed to a manually operated closing and locking device for overhead garage doors. As shown in FIGS. 5 and 6 of Bagley, the locking device includes a latch bolt 55 that interacts with an adjustable vertical keeper plate 56 mounted on a frame 23, which is on the outside of the guide track 25. Bagley does not teach or suggest mounting the keeper plate on the inside of the guide track. FIGS. 5 and 6 of Bagley are shown below.

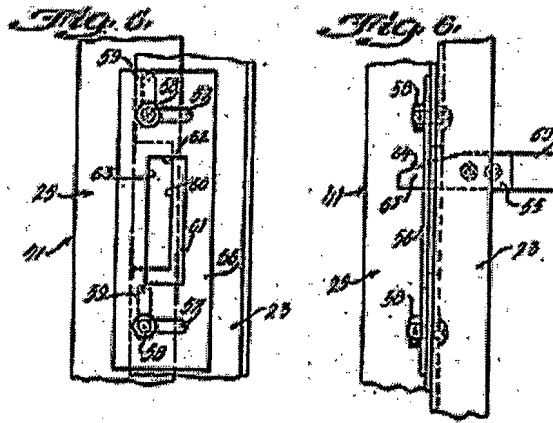

a. There Is No Suggestion or Motivation to Combine Collier and Bagley

“When an obviousness determination is based on multiple prior art references, there must be a showing of some teaching, suggestion, or reason to combine the references.” *Winner International Royalty Corp. v. Wang*, 202 F.3d 1340, 1348 (Fed. Cir. 2000) (citations omitted). *See also In re Stencel*, 828F.2d 751, 755 (Fed. Cir. 1987) (“Nor is obviousness established by combining the teachings of the prior art to produce the claimed invention, absent some teaching or suggestion that the combination be made”).

“Numerous decisions emphasize that such a combination of reference teaching is improper unless the prior art suggests such a combination.” Chisum on Patents §5.04[1][e]. *See Ex parte Dussaud*, 7 USPTO2d 1818, 1820 (Bd. App. & Int’f 1988); *Winner International Royalty Corp. v. Wang*, 202 F.3d 1340, 1348 (Fed. Cir. 2000) (citations omitted). *See also In re Stencel*, 828F.2d 751, 755 (Fed. Cir. 1987). For example, in *In re Bond*, 910 F.2d 831, 15 USPQ2d 1566 (Fed. Cir. 1990), the Court held that the Office erred in rejecting the claimed invention as an obvious combination of the teachings of two prior art references when the prior art provided no teaching, suggestion or incentive supporting the combination. *Id.* at 834-35. “The absence of such a suggestion [to combine] is dispositive in an obviousness determination.” *Gambro Lundia AB v Baxter Healthcare Corp.*, 110 F.3d 1573, 1579 (Fed. Cir. 1997).

Notwithstanding the foregoing law, the Examiner has not sufficiently articulated any motivation or suggestion to combine the teachings of Collier and Bagley. The Examiner has conceded that Collier does not disclose a door guide adapted to retain a door therein “such that the door can move slidably along a length of the guide when the door is retained in the guide.” This is because Collier is directed to a different problem than that to which Bagley and

Applicants' invention are directed. Specifically, Collier is directed to security hardware for traditional sliding glass door and window installations that have a strike plate located on the jamb of the door or window. Nothing in Collier suggests the desirability of locating the strike plate in a guide channel within which the door or window slides. To the contrary, Collier merely reflects the accepted wisdom that a strike plate for a sliding glass door or window should be located in the jamb, outside of any guide channel. If anything, therefore, Collier teaches away from locating the strike plate in a guide channel within which the door slides.

The Examiner has suggested that it would have been obvious to combine the teachings of Collier and Bagley because the Examiner contends that it is well known to use a latch mechanism "similar" to Applicants with a rolling door and that the difference between a rolling door and a sliding door is a "design consideration" that would not affect the latch mechanism. Office Action dated May 15, 2006, at page 3. This assertion ignores the issues associated with a latch for an overhead door versus one located in a jamb for a vertical sliding door (as in Collier). In the former case, as discussed above, even slight height variations between the door guide and the overhead door can result in situations where the latch tongue will not line up with the door guide opening. Moreover, a latch mechanism for an overhead door must not interfere with the operation of the door rollers. Such issues are not a concern with a sliding door latch mechanism, which is mounted in the door jamb.

The Examiner asserts (without citation to authority) that a conclusion of obviousness can be based on "common knowledge" and "common sense" that does not require a specific hint or suggestion in a particular reference. Office Action dated May 15, 2006, at page 6. Such an assertion, however, is not sufficient to establish a *prima facie* case of obviousness without some objective reason to combine the teachings of the references. MPEP § 2143.01 (Assertion that modifications of the prior art would have been "well within the ordinary skill of the art at the time the claimed invention was made" is not sufficient to establish a *prima facie* case of obviousness without some objective reason to combine the teachings of the references.) Yet, the Examiner has not specifically set forth any such objective reason to combine the teachings of Collier and Bagley. Instead, not only do the cited references fail to explicitly provide a suggestion or motivation for such a combination, but they teach away from such a combination. As shown in Bagley, the accepted location of a strike plate for an overhead door is on the outside of the guide track, not on the inside.



Finally, the Examiner seems to suggest that, simply because both references disclose latch strike plates, that is enough for a finding of obviousness. Again, Applicant respectfully disagrees. "The mere fact that the prior art could be modified in the manner proposed by the Examiner would not have made the modification obvious unless the prior art suggested the desirability of the modification." *Ex parte Dussaud*, 7 USPQ2d 1818, 1820 (Bd. App. & Int'f 1988); see MPEP § 2143.01. As discussed above, however, nothing in the prior art suggests the desirability of the asserted combination. Merely because both references show strike plates and the Collier strike plate arguably could be modified for use on the garage door of Bagley is not enough to show obviousness.

In any event, the proposed combination of Collier and Bagley do not disclose a striker plate that can be adjustably affixed directly to the door guide inner surface.

For the foregoing reasons, Applicant respectfully submits that claims 1-10, 14-17 and 22 are patentable over the proposed combination of Collier and Bagley.

b. Collier and Bagley Do Not Disclose the Limitations of Claims 2, 3, 14 and 15

Claims 2, 3, 14 and 15 are grouped separately from claims discussed above because, in addition to the foregoing, they recite "a recessed area on the door guide inner surface."

To establish a *prima facie* case of obviousness, the prior art reference (or references when combined) must teach or suggest all of the claim limitations. See *Litton Systems, Inc. v. Honeywell, Inc.*, 87 F.3d 1559, 1569 (Fed. Cir. 1996); MPEP § 2143. Even if it were proper to combine Collier and Bagley, however, that combination does not teach or suggest all of the recited limitations of claims 2, 3, 14 and 15 and does not render the claims obvious.

The Examiner's proposed combination of Collier and Bagley does not teach or suggest such a recessed area on the door guide inner surface. On the contrary, as shown in FIG. 4 of Collier (see above), the inner surface 23 of the door jamb appears to be flat. Likewise the inner surface of the door guide frame 23 shown in FIG. 5 and 6 of Bagley (see above) is flat.

2. The Subject Matter of Claims 11-13 and 18-21 is Not Obvious Under 35 U.S.C § 103(a) Over Collier in View of Bagley, and Further in View of Roth?<sup>2</sup>

The Examiner contends that claims 11-13 and 18-21 are obvious under 35 U.S.C. § 103(a) over Collier in view of Bagley and further in view of Roth. Applicant respectfully submits that Collier, Bagley and Roth do not render these claims unpatentable because the Examiner has presented no suggestion or motivation to combine the cited references.

a. There Is No Suggestion or Motivation to Combine Collier, Bagley and Roth to Achieve Claims 11-13 and 18

Claims 11-13 and 18 are grouped separately from the claims discussed above because, in addition to the foregoing, they recite “a security device having a latch port for accepting said door latch whereby said security device is affixed to said adjustable striker plate.”

In contrast to claims 11-13 and 18, Roth discloses a closure latch or bolt monitoring device mountable in a door jamb. As with Collier, nothing in Roth suggests the desirability of locating the strike plate in a guide within which a door slides. For the reasons discussed above, Applicant respectfully contends that Roth also fails to provide any suggestion or motivation to combine the teachings of the cited references to achieve the door guide latch slot assembly of claims 11-13 or 18. Applicant respectfully submits, therefore, that claims 11-13 and 18 also are patentable over the combination of Collier, Bagley and Roth.

b. There Is No Suggestion or Motivation to Combine Collier, Bagley and Roth to Achieve Claims 19-21

Claims 19-21 are grouped separately from the claims discussed above because they recite a recessed area on the door guide inner surface and “a security device having a latch receiving port, the security device extending out from the outer surface of the door guide.”

For the reasons discussed above, Applicant also contends that there is no suggestion or motivation to combine the teachings of Collier, Bagley and Roth to achieve the door guide latch slot assembly of claims 19-21. Applicant respectfully submits, therefore, that claims 19, 20 and 21 are patentable over the combination of Collier, Bagley and Roth.

---

<sup>2</sup> Claim 19 is an independent claim. Claims 11-13 depend, either directly or indirectly from claim 1. Claim 18 depends indirectly from claim 14. Claims 20-21 depend, either directly or indirectly from claim 19.

CLAIMS APPENDIX

An appendix containing a copy of the claims involved in the appeal is attached.

EVIDENCE APPENDIX

None.

RELATED PROCEEDINGS APPENDIX

None.

CONCLUSION

Based on the foregoing, it is respectfully requested that the rejection of claims 1-22 be withdrawn and that the claims be allowed.

Dated: April 13, 2007

Respectfully submitted,

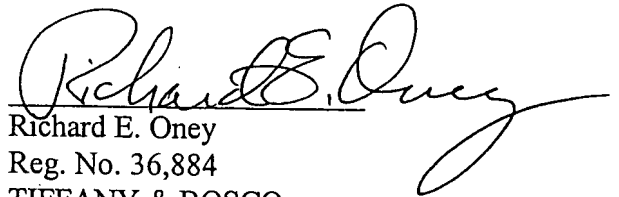

Richard E. Oney  
Reg. No. 36,884  
TIFFANY & BOSCO  
2525 East Camelback Road,  
Third Floor  
Phoenix, Arizona 85016-4237  
Tel: (602) 255-6094  
Fax: (602) 255-0103

**Certificate of Express Mailing under 37 CFR 1.10**

Express Mail Label No. EB 068647583 US

Date of Deposit April 13, 2007

I hereby certify that this paper and all documents and any fee referred to herein are being deposited on the date indicated above with the U.S. Postal Service "Express Mail Post Office to Addressee" service under 37 C.F.R. § 1.10, postage prepaid and addressed to the Mail Stop Appeal Brief-Patents, Commissioner for Patents, P.O. Box 1450, Alexandria, VA 22313-1450.



Louis A. Lofredo, paralegal

4-13-07  
Date of Signature

## CLAIMS APPENDIX

1. (Previously presented) An adjustable door guide latch slot assembly for aligning a slidable door latch with a fixed door guide, the assembly comprising:

a striker plate having a latch opening therein, and a door guide adapted to retain a door therein such that the door can move slidably along a length of the guide when the door is retained in the guide, the guide including an inner surface and an opening therein, with said opening being larger than said striker plate latch opening, whereby said striker plate may be adjustably affixed directly to said door guide inner surface so that said striker plate latch opening aligns with said slidable door latch.

2. (Original) The adjustable latch slot assembly of claim 1, further comprising a recessed area on said door guide inner surface that is large enough so that said striker plate may be placed flat within said recessed area.

3. (Previously presented) The adjustable latch slot assembly of Claim 2 wherein the recessed area has a depth that is at least as great as a thickness of said striker plate.

4. (Original) The adjustable latch slot assembly of Claim 1 wherein said door guide opening has alignment slots for accommodating various positions of placement of said striker plate against said door guide inner surface.

5. (Original) The adjustable latch slot assembly of Claim 2 wherein said door guide opening has alignment slots for accommodating various positions of placement of said striker plate against said door guide inner surface.

6. (Original) The adjustable latch slot assembly of Claim 3 wherein said door guide opening has alignment slots for accommodating various positions of placement of said striker plate against said door guide inner surface.

7. (Original) The adjustable latch slot assembly of Claim 2 wherein said striker plate has a first set of fastener openings for receiving fasteners to affix said striker plate to said door guide.

8. (Original) The adjustable latch slot assembly of Claim 3 wherein said striker plate has a first set of fastener openings for receiving fasteners to affix said striker plate to said door guide.

9. (Original) The adjustable latch slot assembly of Claim 4 wherein said striker plate has a first set of fastener openings for receiving fasteners to affix said striker plate to said door guide.

10. (Original) The adjustable latch slot assembly of Claim 6 wherein said striker plate has a first set of fastener openings for receiving fasteners to affix said striker plate to said door guide.

11. (Original) The adjustable latch slot assembly of Claim 1 further comprising a security device having a latch port for accepting said door latch whereby said security device is affixed to said adjustable striker plate to accommodate the position of said door latch.

12. (Original) The adjustable latch slot assembly of Claim 3 further comprising a security device having a latch port for accepting said door latch whereby said security device is affixed to said adjustable striker plate to accommodate the position of said door latch.

13. (Original) The adjustable latch slot assembly of Claim 4 further comprising a security device having a latch port for accepting said door latch whereby said security device is affixed to said adjustable striker plate to accommodate the position of said door latch.

14. (Previously presented) An adjustable door guide latch slot assembly for aligning a slidable door latch with a fixed door guide, the assembly comprising:

a striker plate having a latch opening therein and a door guide adapted to retain a door therein such that the door can move slidably along a length of the guide when the door is retained in the guide, the guide including an inner surface, with a recessed area on said inner surface, said recessed area being larger than said striker plate, the inner surface further having an opening therein, with said opening being larger than said striker plate latch opening, whereby said striker plate may be placed flat against said door guide inner surface in said recessed area and adjustably affixed to said door guide inner surface so that said striker plate latch opening aligns with said slidable door latch.

15. (Original) The adjustable latch slot assembly of Claim 14 wherein the depth of said recessed area is at least as great as the thickness of said striker plate.

16. (Original) The adjustable latch slot assembly of Claim 15, whereby said door guide opening has alignment slots for accommodating various positions of said striker plate against said door guide inner surface.

17. (Original) The adjustable latch slot assembly of Claim 16 further comprising a first set of fastener openings in said striker plate for affixing said striker plate to said door guide.

18. (Original) The adjustable latch slot assembly of Claim 17 further comprising a security device having a latch receiving port for accepting said door latch whereby said security device is affixed to said adjustable striker plate so that said security device latch receiving port aligns with said slidable door latch.

19. (Previously presented) An adjustable door guide latch slot assembly for aligning a slidable door latch with a fixed door guide, the assembly comprising:

a striker plate having a latch opening therein;

a door guide adapted to retain a door therein such that the door can move slidably along a length of the guide when the door is retained in the guide, the guide including an outer surface and an inner surface with a recessed area larger than said striker plate and having an opening therein extending from the inner surface to the outer surface, with said opening being larger than said striker plate latch opening; and

a security device having a latch receiving port, the security device extending out from the outer surface of the door guide,

whereby said striker plate may be placed flat against said door guide inner surface within said recessed area and may be adjustably affixed to said door guide inner surface so that said striker plate latch opening aligns with said slidable door latch and whereby said security device is affixed to said adjustable striker plate so that said latch receiving port aligns with both said striker plate latch opening and said slidable door latch.

20. (Original) The adjustable latch slot assembly of Claim 19 wherein the depth of said recessed area is at least as great as the thickness of said striker plate.

21. (Original) The adjustable latch slot assembly of Claim 20 wherein said door guide opening further comprises alignment slots for accommodating various positions of said striker plate against said door guide inner surface.

22. (Previously presented) A method of adjustably aligning a latch slot in a fixed door guide with a slidable door latch comprising the steps of:

providing a striker plate having a latch opening therein; and

providing a door guide having a channel sized to retain a door slidably therein, the channel including an inner surface and an opening therein, with said opening being larger than said striker plate latch opening,

whereby said striker plate may be adjustably affixed to said door guide inner surface so that said striker plate latch opening aligns with said slidable door latch.



EVIDENCE APPENDIX

None.

RELATED PROCEEDINGS APPENDIX

None.